



# Interaction between individual experience and social learning in dogs

PÉTER PONGRÁCZ\*, ÁDÁM MIKLÓSI\*, ENIKŐ KUBINYI\*, JÓZSEF TOPÁLT † & VILMOS CSÁNYI\*

\*Department of Ethology, Eötvös Loránd University

†Comparative Ethology Group, Hungarian Academy of Sciences

(Received 29 November 2001; initial acceptance 7 January 2002;  
final acceptance 7 August 2002; MS. number: 7148R)

We investigated the interaction between individual experience and social learning in domestic dogs, *Canis familiaris*. We conducted two experiments using detour tests, where an object or food was placed behind a transparent, V-shaped wire-mesh fence, such that the dogs could get the reward by going around the fence. In some groups, two open doors were offered as an alternative, easier way to reach the reward. In experiment 1 we opened the doors only in trial 1, then closed them for trials 2 and 3. In experiment 2 other dogs were first taught to detour the fence with closed doors after they had observed a detouring human demonstrator, then we opened the doors for three subsequent trials. In experiment 1 all dogs reached the reward by going through the doors in trial 1, but their detouring performance was poor after the doors had been closed, if they had to solve the task on their own. However, dogs in the experimental group that were allowed to watch a detouring human demonstrator after the doors had been closed showed improved detouring ability compared with those that did not receive a demonstration of detouring. In experiment 2 the dogs tended to keep on detouring along the fence even if the doors had been opened, giving up a chance to get behind the fence by a shorter route. These results show that dogs can use information gained by observing a human demonstrator to overcome their own mistakenly preferred solution in a problem situation. In a reversed situation social learning can also contribute to a preference for a less adaptive behaviour. However, only repeated individual and social experience leads to a durable manifestation of maladaptive behaviour.

© 2003 Published by Elsevier Science Ltd on behalf of The Association for the Study of Animal Behaviour.

Interest in social learning among individuals has led to a number of laboratory studies showing that in solving a novel task naïve animals can benefit from watching skilled demonstrators (e.g. Zentall & Hogan 1978; Palameta & Lefebvre 1985; Heyes 1994; Galef 1995). However, under natural conditions social learning is not the only way to gain the skills needed for solving a task. The behaviour of an individual is also influenced by experience, and concurrent trial and error learning might also interact with socially acquired information (Heyes 1993; Galef 1995). Galef & Whiskin (2001) showed that if rats, *Rattus norvegicus*, are given the opportunity to sample their environment continuously, socially acquired behaviour diminishes faster; that is, socially acquired taste preference became less pronounced when rats were allowed to eat another type of food. These results underline the notion that, to establish the

Correspondence: P. Pongrácz, Department of Ethology, Eötvös Loránd University, Budapest, Pázmány Péter sétány 1/c, H-1117 Hungary (email: uupeter@ludens.elte.hu). J. Topál is at the Comparative Ethology Group, Hungarian Academy of Sciences, Budapest, Pázmány Péter sétány 1/c, H-1117 Hungary.

contribution of social-learning processes to the overall fitness of an individual, one should investigate this phenomenon in relation to both alternative forms of (asocial) learning and the influence of experience.

Domestic dogs, *Canis familiaris*, can benefit from observing conspecifics in problem-solving tasks (Adler & Adler 1977; Slabbert & Rasa 1997). Learning by observing humans is also possible since the majority of dogs spend most of their life among humans. Recently we showed how social learning improves the performance of dogs facing a new problem (Pongrácz et al. 2001b). Observer dogs watching a human demonstrator walking around a V-shaped fence and carrying a target object behind it detoured the fence more quickly than dogs that did not witness the human action. Dogs' sensitivity to human behaviour seemed to offer a good opportunity to investigate the interaction between individual experience and social learning. Wolves, *Canis lupus*, are known to be extremely good problem-solvers on their own (Frank 1980). In contrast, the human environment offers a rich opportunity for social learning in the domestic dog. The domestication process may have led to changes in dogs'

behaviour that transferred emphasis from individual problem-solving ability to docility and trainability. In our earlier study (Pongrácz et al. 2001b) dogs were naïve about the task presented to them, and they had no alternative way of solving the problem. The rationale for the present study was to provide the dogs with both social and individual learning experience and observe how they integrate information obtained through these different 'channels'. In experiment 1 we investigated (1) whether dogs are able to switch to a novel alternative behaviour if individual experience gained at a previously successful problem-solving attempt no longer leads to the goal, and (2) whether their willingness to change their behaviour could be enhanced by social learning. For the first trial all dogs were allowed to retrieve an object by going through an open door in the fence. On the next trial the door was closed, and half of the dogs were given the chance to solve the task on their own while the other half were exposed to a human demonstrating a detour. We predicted that dogs observing a demonstrator would be quicker to switch to the detouring behaviour. In experiment 2 we investigated the extent to which both socially and individually acquired experience influence behaviour that becomes maladaptive in a novel context. After dogs learned by observation to detour the V-shaped fence, we opened a door on both sides of the fence that offered a much more direct path to the object. We also tried to make the dogs aware of the open doors but did not demonstrate how to get through them. If dogs base their problem solving on the situation at hand and not on a previously learned skill, we expected dogs facing the open door to give up detouring and approach the object directly through the newly opened doors.

## GENERAL METHODS

### Subjects

Dogs ( $N=86$ ) and their owners were recruited from volunteer participants of a dog training school and competitions for dogs. Because volunteer numbers were often limited, the group sizes varied slightly. Owners were instructed how to behave and what to do (and not to do) during the test. Dogs were included in these experiments only if the owner followed our instructions. They were assigned randomly among the experimental groups and each dog was tested in only one condition.

Only dogs older than 1 year were tested ( $\bar{X} \pm SD = 3.0 \pm 2.4$  years), and we included dogs from a variety of breeds (see Appendix). The overall sex ratio of dogs was balanced (M/F: 41/45) and we also tried to balance the sex ratio of the experimental groups. The majority of dogs had female owners (M/F: 20/66).

### Procedure

All tests were performed outdoors in the late summer and autumn of 2000. For the tests, we used a V-shaped

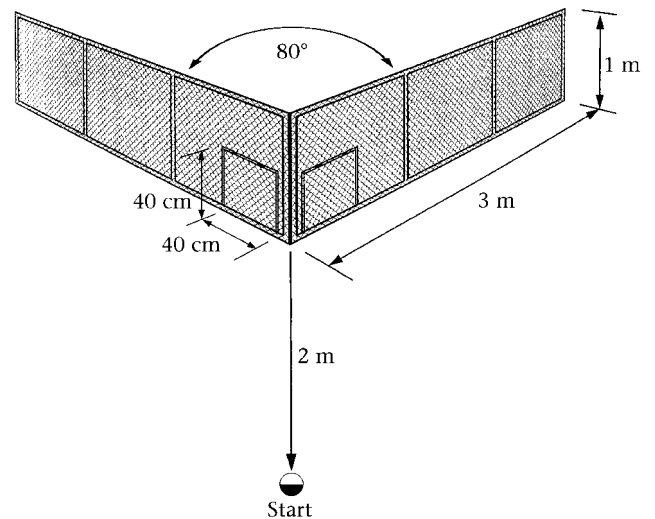

Figure 1. Drawing of the V-shaped experimental fence. The two doors (40×40 cm) could be fixed open or closed.

fence 1 m high, with sides 3 m long closing an angle of 80° (Fig. 1). The fence was made of thin, transparent wire mesh, with a hole diameter of 20 mm, set on to a steel frame. Two swing-doors (0.4 × 0.4 m) were mounted into the front section of both sides of the fence. The doors could be opened upwards and into the fence and could be fixed in either an open or a closed position. The size of the doors allowed even the largest dogs (great dane) to go through them easily. We set up the fence by pushing the pegs protruding from the frame into the ground. The frame of the fence prevented the dogs digging under it. To dissipate any scent marks, after setting up the fence and before the first dog's trials, the experimenter made tracks in the grass along both sides of the fence (including the inner side) 10 times in both directions. Usually several dogs belonging to different experimental groups were tested in the same experimental session, so several scent trails were laid on each other. This made it difficult for the dogs to follow the scent mark of either the demonstrator or the dogs.

The starting line was set at 2 m from the intersecting angle of the fence where both the dog and the owner had to stand at the beginning of the trials. The task of the dogs was to get a piece of food or a favourite toy (target objects) by detouring along the fence. Before the test we asked the owner which object would be more appropriate for motivating the dog. If both a toy and food were proposed, we used the toy.

The test consisted of a series of 1-min detour trials that were started one after the other with short (1–3 min) intertrial intervals. Besides the owner, the experimenter and an assistant were present. The latter videotaped the test from behind the experimenter and the owner. The experimenter stood up to 1 m behind the owner. During the trials the owner was asked to encourage the dog to reach the goal object but had to stay on the starting line and was asked not to command the dog to go around either verbally, or via gestures given by hand or other body parts. Owners were not informed of the

**Table 1.** The conditions of the experimental groups in experiment 1

	Closed door		Open door	
	Without demonstration	With demonstration	Without demonstration	With demonstration
Trial 1				
Door	Closed	Closed	Open	Open
Detour demonstration	No	No	No	No
Trial 2				
Door	Closed	Closed	Closed	Closed
Detour demonstration	No	Yes	No	Yes
Trial 3				
Door	Closed	Closed	Closed	Closed
Detour demonstration	No	Yes	No	Yes

experimental hypotheses beforehand, and were asked only to encourage the dogs with common commands such as ‘Where is the ball?’ ‘Come on, fetch the ball!’.

### Data Collection and Analysis

We measured the latency to obtain the target by the dog. Latency was defined as the time elapsed between the dog’s release from the leash and its taking the target in its mouth. Latency was analysed by single, repeated measures or mixed ANOVAs and a Student–Newman–Keuls post hoc test.

We analysed the dogs’ behaviour from the videotaped sequences of their trials. If the doors were open, we recorded whether the dogs detoured the fence or used the door. We analysed the results with a Fisher’s exact test, to see whether they differed significantly from the reference level of choice between usage of the doors or detouring. Naïve dogs always chose the door to get to the target, if the doors were open; therefore the reference level for door use was set at 100%. In experiment 2 we also recorded from the videotape the frequency of gazing in three directions: (1) at the nearest door; (2) at a 30-cm section of the fence before and after the given door; (3) under the door: a 10-cm-high zone of the fence between the lower edge of the door and the ground. We could analyse gazing behaviour only when the dogs stayed within a 1-m section at the front of the fence. Gazing towards a given direction was determined by the orientation of the dog’s nose. A dog’s viewing angle (ca. 250° considering both eyes) allows it to see in a wider space than the direction of the gaze but the orientation of its head indicates the most probable target of gazing. We analysed these data with repeated measures ANOVA and a Student–Newman–Keuls post hoc test (within-group comparison) and one-way ANOVA and a Student–Newman–Keuls post hoc test (between-groups comparison). We also performed a reliability test on the gaze analysis. Two independent observers’ simultaneous measurements of the whole sample were compared with a Pearson correlation (Caro et al. 1979).

### EXPERIMENT 1

Although dogs experience difficulties in solving problems involving detours, they can learn to solve such tasks by trial and error or by observation of demonstrators (Pongrácz et al. 2001b). Trial and error learning, however, is slow; dogs needed five or six trials to show significant improvement, in contrast to learning by observation where one trial was sufficient. Preliminary observations showed that in the same situation as our present study, dogs could obtain the target without difficulty if they could reach it through an opening near the intersecting angle of the fence. This provided us with the opportunity to investigate how individual experience (getting the target through the opening) and social learning (observing a detouring human) might interact in the development of problem-solving behaviour.

### Methods

We used four experimental groups (Table 1), with three experimental trials for each. In two groups the doors were closed during all three trials. In the other two groups the doors were opened in trial 1, and closed in trials 2 and 3.

#### *Closed door without detour demonstration*

Dogs were included in this group only if they mastered the first trial within 60 s but their latency was longer than 10 s ( $N=14$ ).

Both doors were closed during the three identical trials. The experimenter placed the target behind the V-shaped fence near the inner side of the intersecting angle, while the owner crouched in front of the dog and covered its eyes with her/his hands to prevent it seeing the actions of the experimenter. When the experimenter returned to the starting point, the owner led the dog on a leash to the intersecting angle of the fence and showed it the target. The wire mesh of the fence was thin and transparent, so the target was clearly visible behind it. After returning to the starting point, the owner unleashed the dog. If the

dog obtained the target, the owner praised it verbally, played with it, or allowed it to eat the food. Trials lasted for a maximum of 1 min. If the dog was not able to obtain the target within 1 min (in trials 2 or 3), the trial was terminated and we recorded the latencies of these trials as 60 s in the subsequent analysis. In trials 2 and 3 the dog was not allowed to examine the object before the trial.

#### *Closed door with detour demonstration*

Dogs were assigned to this group only if their latency of detouring in trial 1 was 10–60 s ( $N=14$ ).

Both doors remained closed during all three trials. The first trial was identical to that described for the Closed Door without Detour Demonstration group. In trials 2 and 3 the owner stayed with the dog at the starting point, but did not cover its eyes. Instead, the owner and the experimenter encouraged the dog to watch the experimenter continuously as he/she carried the target object behind the fence. The experimenter made the detour by walking near one side of the fence, conspicuously put the object down, showed his/her empty hands, then left the fence, walking along the other side. After the experimenter returned to the starting point, the owner unleashed the dog and encouraged it to obtain the target. The direction of the demonstrative detours was counter-balanced between trials and dogs.

#### *Open door without detour demonstration*

In this condition we used 10 dogs. Before the first trial we fixed the doors in the open position. While the owner was covering the eyes of the dog at the starting point, the experimenter placed the object behind the fence. After the experimenter returned to the starting point, the owner led the dog on the leash to the intersecting angle of the fence and showed it the target. The trial started when the owner unleashed the dog from the starting point. After trial 1 the owner played with the dog and diverted its attention from the fence, while the experimenter fixed the doors in the closed position. Trials 2 and 3 were the same as in the Closed Door without Detour Demonstration group.

#### *Open door with detour demonstration*

In this condition we used 13 dogs. The first trial was the same as in the Open Door without Detour Demonstration group. After trial 1 we closed the doors. Trials 2 and 3 were the same as in the Closed Door with Detour Demonstration group.

## Results and Discussion

We analysed the effect of the repetition of the trials (within-subject factor) and the experimental group (between-subject factor) with mixed ANOVA for repeated measures to the within-subject factor. The repetition of the trials had a significant effect on the latency to reach the target ( $F_{2,94}=10.66$ ,  $P<0.001$ ; Fig. 2). The experimental groups showed significant differences ( $F_{3,47}=5.61$ ,  $P<0.01$ ), and the interaction was also significant ( $F_{6,94}=22.65$ ,  $P<0.001$ ). Latencies in the Closed Door

without Detour Demonstration group did not decrease significantly over the trials (one-way ANOVA with repeated measures:  $F_{2,26}=0.12$ ,  $P=0.89$ ), in contrast to those of dogs that were allowed to watch a demonstrator (Closed Door with Detour Demonstration group:  $F_{2,26}=17.19$ ,  $P<0.001$ ). As expected, both groups with open doors obtained the target through the door in trial 1, which led to increased latencies in subsequent trials, when the doors were closed (Open Door without Detour Demonstration:  $F_{2,18}=44.43$ ,  $P<0.001$ ; Open Door with Detour Demonstration:  $F_{2,24}=9.93$ ,  $P<0.001$ ). In both groups with opened doors latencies were significantly shorter in trial 1 than in trials 2 and 3 (Fig. 2). In contrast, the latency in trial 1 was significantly longer than in trials 2 and 3 in the Closed Door with Detour Demonstration group. Latencies differed significantly between groups for all trials (one-way ANOVA: trial 1:  $F_{3,47}=12.32$ ,  $P<0.001$ ; trial 2:  $F_{3,47}=7.61$ ,  $P<0.001$ ; trial 3:  $F_{3,47}=18.58$ ,  $P<0.001$ ).

Dogs in the two open-door groups reached the target significantly faster in trial 1 than did the dogs with closed doors (Fig. 3). In trial 2 the dogs in the Open Door without Detour Demonstration group had significantly longer latencies than the dogs in all the other groups. In trial 3 the dogs in the Closed Door with Detour Demonstration group had the shortest latencies, while dogs in the Open Door without Detour Demonstration had the longest latencies.

As expected, all dogs in both groups with open doors chose the shorter way to reach the target through one of the openings, so their latencies were considerably shorter than those of dogs that had to detour the fence. In agreement with our previous experiments (Pongrácz et al. 2001b), dogs in the Closed Door with Detour Demonstration group showed a significant improvement in the speed of detouring when given the opportunity to observe a human demonstrator before trials 2 and 3. At the same time dogs in the Closed Door without Detour Demonstration group did not show any change in their detour performance.

Dogs in the Open Door without Detour Demonstration group found it almost impossible to get behind the fence by detouring after the doors had been closed. As our earlier study showed (Pongrácz et al. 2001b), dogs seemed to be inclined to repeat their previous successful actions. This kind of persistence is reflected in that here the majority of these dogs (70%) did not get behind the fence during the 60 s allowed, and that their latencies were much higher than those of dogs that did not experience an open door (Closed Door without Detour Demonstration group; Fig. 3) even in trial 3. We conclude that the elimination of a previously successful way to solve the task (i.e. closing the doors) set back the dogs' performance.

In contrast, social learning was present in the Open Door with Detour Demonstration Group. The latencies of these dogs were significantly shorter than those from the Open Door without Detour Demonstration group. Although closing the door resulted in poorer detouring abilities in trials 2 and 3, compared with dogs in the Closed Door with Detour Demonstration group, these animals were able to use information obtained by

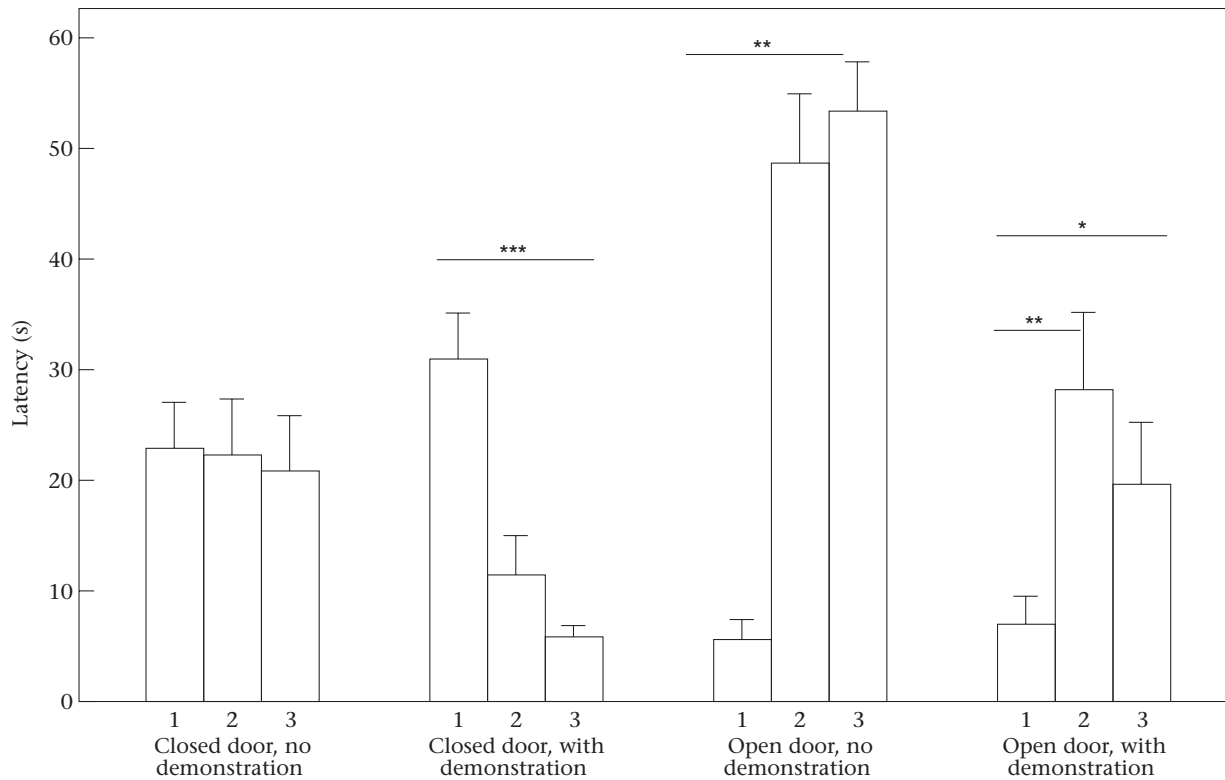

**Figure 2.** The latencies ( $\bar{X} \pm SE$ ) for reaching the target in the Closed Door without and with Detour Demonstration groups, and in the Open Door without and with Detour Demonstration groups in three consecutive trials (experiment 1). Trial numbers are given below the bars. Significant differences between trials within a group are indicated with asterisks (Student–Newman–Keuls post hoc test: \* $P < 0.05$ ; \*\* $P < 0.01$ ; \*\*\* $P < 0.001$ ).

observation to overcome their difficulties. We conclude that social learning was effective in changing the behaviour pattern of a dog solving a difficult problem.

## EXPERIMENT 2

The results of experiment 1 showed that, if given a choice between detouring and using the doors, naïve dogs preferred to get the target through an opening in the V-shaped fence. Therefore using the opening can be regarded as an advantageous strategy that saves both time and energy. In experiment 2 we tried to reverse the situation, and ask whether a socially acquired behaviour pattern would survive even if changes in the environment favoured a different and simpler solution. In particular we asked whether dogs would abandon a socially acquired detouring behaviour if they were presented with an opening in the fence. We also tested whether the number of demonstrations of detours (and the simultaneous experience of dogs in making detours) has an effect on the persistence of detouring over the use of doors. For this reason we formed groups with different experience of detours.

### Methods

The set-up was the same as described above. Before the experiment dogs were allowed to detour the fence in

1-min-long sessions that were identical to those described for the Closed door with Detour Demonstration group in experiment 1. As we have shown, this demonstration led to a confident detouring of the V-shaped fence. The behaviour of the experimental groups was observed in the next three trials.

#### *Open door with three detour demonstrations*

After finishing the third a priori detouring trial, the owner turned the dog away from the fence and played with it. During this short interval the experimenter fixed the doors in the open position and placed the target behind the fence. The first trial started when the experimenter returned to the starting position, and the owner turned the dog back towards the fence and encouraged it to obtain the target ( $N=13$ ). Trials 1–3 lasted for 60 s each.

Before trial 2 the owner did not cover the eyes of the dog, but encouraged it to watch the experimenter's actions. The experimenter went to the fence, crouched beside a randomly chosen door and conspicuously placed the target inside the fence through the door. Meanwhile, the experimenter talked to the dog (e.g. 'Watch me'). When the experimenter returned to the starting position, the owner unleashed the dog and encouraged it to obtain the target. This process was repeated for trial 3 except that the experimenter placed the target inside the fence through the other door.

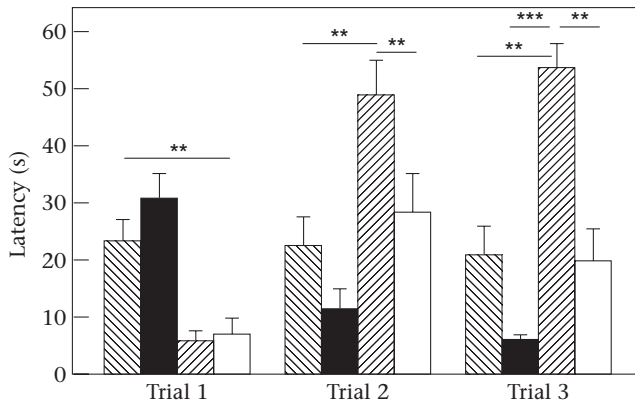

**Figure 3.** The latencies ( $\bar{X} \pm SE$ ) for reaching the target in each trial in the Closed Door without (▨) and with (■) Detour Demonstration groups, and in the Open Door without (▧) and with (□) Detour Demonstration groups (experiment 1). Significant differences between groups within a trial are indicated with asterisks (Student–Newman–Keuls post hoc test: \* $P < 0.05$ ; \*\* $P < 0.01$ ; \*\*\* $P < 0.001$ ).

#### Open door with single detour demonstration

The dogs ( $N=11$ ) received only one a priori demonstration trial before the doors were opened. The three trials were executed similarly to trials 1–3 in the Open Door with Three Detour Demonstrations condition.

#### Closed door group

Dogs in this group ( $N=11$ ) received three a priori detour demonstrations, like the dogs in the Open Door with Three Detour Demonstrations condition. Subsequently, the doors remained closed during the three trials. These trials were identical to those run with dogs in the Closed Door without Detour Demonstration group in experiment 1.

## Results and Discussion

The percentages of dogs that chose one of the doors in the Open Door with Three Detour Demonstrations group were as follows: trial 1: 0%; trial 2: 31.77%; trial 3: 23.08%. Percentages were similar in the three trials in the Open Door with Single Detour Demonstration group (trial 1: 55%; trial 2: 55%; trial 3: 73%; Fig. 4). The results of experiment 1 suggested that dogs use the open doors if provided. Therefore we compared the performance of the dogs in the present experiment to an assumed level of 100% door use (Fisher's exact test). During trial 1 the dogs in the Open Door with Three Detour Demonstrations group obtained the target only by detouring the fence, and in trials 2 and 3 they also preferred detouring versus using the doors ( $P < 0.001$  for each trial). The usage of the doors in the Open Door with Single Detour Demonstration group differed from the estimated 100% level in trials 1 and 2 ( $P < 0.01$ ), but not in trial 3 ( $P = 0.08$ ; Fig. 4). We also compared the solutions between the two open-door groups (Fisher's exact test). Dogs with three detour demonstrations used the doors significantly less than dogs with single demonstrations in trial 1 ( $P < 0.01$ ), but not in trials 2 ( $P = 0.21$ ) and 3 ( $P = 0.10$ ).

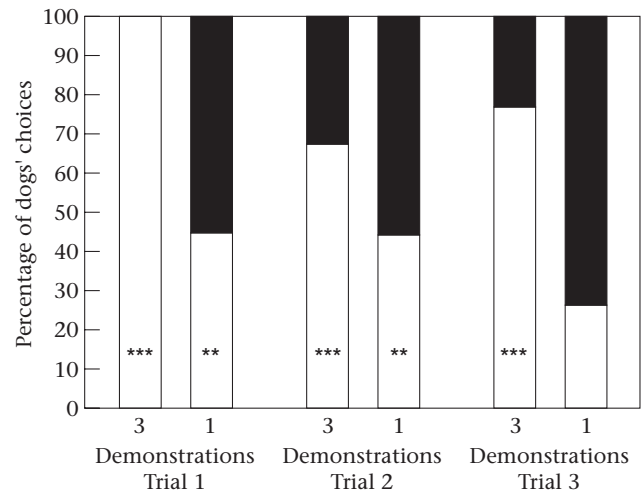

**Figure 4.** The percentage of dogs that chose one of the doors (■) or detoured the fence (□) in the open-door groups with either three or one detour demonstrations in trials 1–3 (experiment 2). Earlier these dogs detoured during three and one trials, respectively, with closed doors. Significant differences from the reference level (100%) are indicated with asterisks (Fisher's exact test: \* $P < 0.05$ ; \*\* $P < 0.01$ ; \*\*\* $P < 0.001$ ).

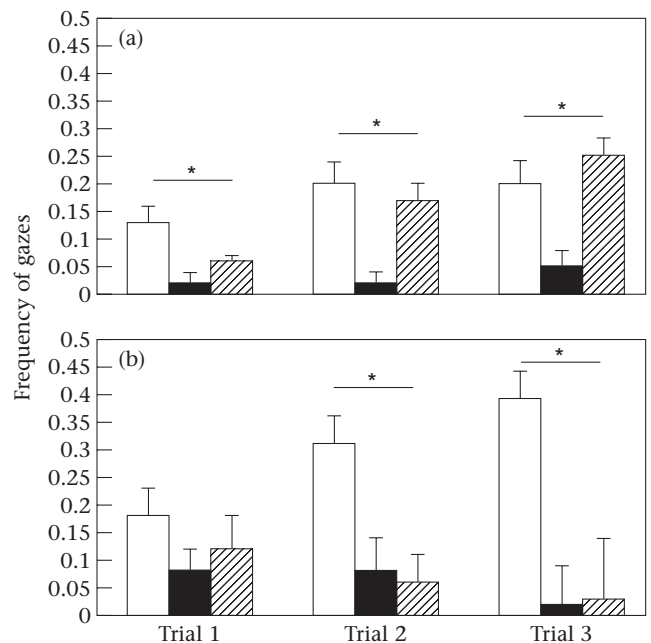

**Figure 5.** Frequency of gazing ( $\bar{X} \pm SE$ ) at the nearest door (□), beside the door (■) and under the door (▧) during three consecutive trials in (a) the Open Door with Three Detour Demonstrations group, and (b) the Open Door with Single Detour Demonstration group (experiment 2). Significant differences within a trial are indicated with asterisks (Student–Newman–Keuls post hoc test: \* $P < 0.05$ ; \*\* $P < 0.01$ ; \*\*\* $P < 0.001$ ).

We compared the frequency of the dogs' gazes in three directions during the trials (Fig. 5). For a reliability test, we pooled the trials of the three experimental groups, and analysed the results of the three gaze directions separately. Pearson correlation tests between two observers'

simultaneous measurements on gaze direction showed that our method was reliable (gazing at the door:  $r_{103}=0.95$ ,  $P<0.001$ ; beside the door:  $r_{103}=0.95$ ,  $P<0.001$ ; under the door:  $r_{103}=0.89$ ,  $P<0.001$ ). The dogs in the Closed Door group looked equally in the three directions (repeated measures ANOVA: trial 1:  $F_{2,20}=0.63$ ,  $P=0.12$ ; trial 2:  $F_{2,20}=3.66$ ,  $P=0.05$ ; trial 3:  $F_{2,20}=1.58$ ,  $P=0.23$ ). In contrast, dogs in the Open Door with Three Detour Demonstrations group gazed mainly at and under the door when they approached the front section of the fence (repeated measures ANOVA: trial 1:  $F_{2,24}=9.59$ ,  $P<0.001$ ; trial 2:  $F_{2,24}=10.58$ ,  $P<0.001$ ; trial 3:  $F_{2,24}=12.08$ ,  $P<0.001$ ). Dogs in the Open Door with Single Detour Demonstration group gazed mainly at the door in trials 2 and 3 (trial 1:  $F_{2,20}=0.85$ ,  $P=0.44$ ; trial 2:  $F_{2,20}=7.21$ ,  $P<0.01$ ; trial 3:  $F_{2,20}=39.67$ ,  $P<0.001$ ). We also compared the three groups with regard to the frequency of their gazes in the three directions during the trials (one-way ANOVA). Dogs in the Closed Door group looked significantly less at the door than the dogs in the two groups with open doors during all trials. Dogs in the Open Door with Three Detour Demonstrations group also looked more under the door in trials 2 and 3. There was no significant difference in the frequency of gazes beside the doors.

Compared with the dogs in experiment 1, where naïve animals were confronted with the open doors in the first trial, here experienced detourers encountered the open doors in the last three trials. However, while all the dogs in experiment 1 used the door to reach the target, only a small proportion did the same in experiment 2. The latencies of the dogs in the Open Door with Three Detour Demonstrations group in the first trial were significantly higher (one-way ANOVA:  $F_{2,33}=12.37$ ,  $P<0.001$ ) than the latencies of the dogs in the Open Door with Single Detour Demonstration group, or the first trial latencies of the pooled groups with an open door from experiment 1 (Fig. 6). This result indicates that the more dogs chose the doors to reach the object, the shorter the latency of the group became in the actual trial. This difference is especially striking because all dogs in the Open Door with Three Detour Demonstrations group chose to detour passing near the open door in trial 1. Furthermore, about 75% of these dogs persisted in detouring even in trial 3 after they had observed the experimenter showing the way to reach the object through the door for the second time. More dogs in the Open Door with Single Detour Demonstration group chose the doors over detouring than in the Open Door with Three Detour Demonstrations group. This result shows that the number of repetitions and experience might have contributed to this effect. However, after even a single detour half of the dogs persisted in detouring during two consecutive trials with open doors. This shows the effectiveness of demonstration paired with successful experience.

Behavioural evidence also suggests that dogs in both open-door groups noticed the change (the opening of the door). The analysis of the frequency of gazes towards the different parts of the first section of the fence revealed that dogs tested with open doors looked more often at the openings than did dogs in the trials with closed doors.

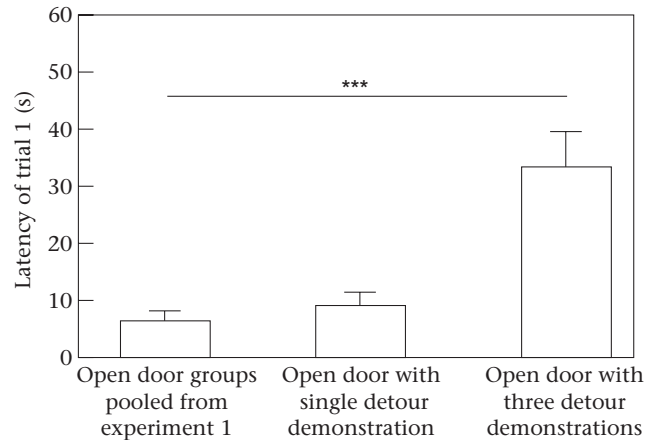

**Figure 6.** Comparison between latencies ( $\bar{X}$ +SE) during trial 1 of the dogs tested with open doors. The first bar represents the pooled data from the two open-door groups from experiment 1, with no a priori detour experience. The other two bars represent the latencies of open-door groups from experiment 2 with one or three detour demonstrations, respectively. Significant differences are indicated with asterisks (Student–Newman–Keuls post hoc test: \*\*\* $P<0.001$ ).

Furthermore, they stared at the opened door more frequently than under or beside it, but we did not find such a difference if the doors were closed.

## GENERAL DISCUSSION

Our results show that (1) all naïve dogs preferred to use the doors to obtain the target from behind the fence; (2) when we closed the doors these dogs had difficulty solving the task by detouring the fence within 60 s; (3) demonstration of detouring strongly increased the dogs' chances of successfully solving the task, when the doors were closed and detouring was the only possible solution; (4) dogs that socially acquired the detouring behaviour only slowly abandoned this behaviour when they were shown a simpler, alternative way of solving the problem (however, the experimenter did not demonstrate exactly the action of crawling through the door, but only placed the target through the door by hand).

Early investigations (e.g. Buytendijk & Fischel 1932) indicated that dogs were able to solve detour tasks only after a long trial-and-error process, and they needed several exposures to the problem to adopt the shortest and quickest solution. However, the presence of a demonstrator could alter the situation profoundly, since many assume that during domestication dogs have been selected for attending to humans (Gácsi et al. 2001), and this might have resulted in a genetic predisposition to treat humans as conspecifics (McBride 1995), in addition to the effect of the early socialization in the human environment that dogs experience when reared with humans (Frank 1980). These suggestions are reflected in the ability of dogs to perceive and respond to human communicative gestures (Miklósi et al. 2000; Soproni et al. 2001, 2002) and probably to verbal utterances (Pongrácz et al. 2001a).

Both of our experiments revealed the complex interaction between asocial (individual) and social learning that must be taken into account to understand how learning abilities in general contribute to increased fitness in animals. In experiment 1 social learning was advantageous in a situation where experience constrained the dogs' behaviour. On the other hand in experiment 2, dogs facing a novel situation and exposed to socially provided information regarding access to the target were reluctant to change their behaviour, showing a preference for the more conservative (and socially learned) behaviour.

Others (Laland 1996; Laland et al. 1996; Laland & Williams 1998) have pointed out that in certain situations social learning could provide individuals with maladaptive information. However, exploring or developing new solutions and habits without learning from others could also be dangerous, for example when predators (Magurran & Higham 1988) or competitors from another social group are present. Therefore in certain circumstances gains at the individual level outweigh the seemingly disadvantageous or maladaptive information that is transferred socially. This could be especially true for the dog. The closest wild relative of the dog, the wolf, is a highly social predator whose pack-hunting habits and well-organized social hierarchy require the ability to follow the behaviour of other pack members. Domestic dogs seem to have retained these skills, and probably expanded them to include human companions. We and others (e.g. Frank 1980; Paxton 2000) argue that the dog has a long history of domestication favouring adaptation to human sociality and behaviour. From this point of view not behaving like humans could be maladaptive for dogs. In the present study dogs from different breeds (Appendix) performed the detour task with similar success. Because not all breeds have been selected to attend to humans, similar performance across breeds in our experiments shows the generality of high-level interest towards human activity by pet dogs.

Considering that naïve dogs uniformly preferred to reach the target through the open doors in experiment 1, the detouring behaviour of the dogs in the presence of the open doors in experiment 2 seems to be disadvantageous. Reaching the target through the door required a significantly shorter latency than detouring the fence, even if dogs detoured very quickly in trial 1 in experiment 2. Two nonexclusive possibilities could explain why these animals did not choose the shorter way. First, dogs might have established a habit of detouring. There are many examples in the animal-learning literature that animals continue to respond to stimulation or to behave in a routine manner long after the withdrawal of the 'reinforcement' (see Kubinyi et al., *in press*, for another example in dogs). Considering dogs as animals with heightened attention towards, and motivation to learn from, humans, the persistence of dogs in detouring might be the natural response in a situation of choice, because the use of the doors was not demonstrated fully. Second, repeating a previously successful action could also be an advantageous trait or strategy in a human environment

that is relatively stable but in some cases too complex for dogs.

Given the effectiveness of socially provided information in changing the behaviour of the dogs in experiment 1, it remains to be answered why dogs did not learn from observation in experiment 2, when the experimenter overtly placed the target through the open door behind the fence in trials 2 and 3 (Open Door with Three Detour Demonstrations group and partly the Open Door with Single Detour Demonstration group, experiment 2). The habit of detouring acquired over one or even three trials might have been too strong to be inhibited by this observation. The results of the Open Door with Single Detour Demonstration group reinforces the quantitative explanation that the more experience a dog has with one of the solutions, the harder it is to abandon this habit later. Dogs in the Open Door with Single Detour Demonstration group detoured the fence less frequently, but instead chose the doors more often. In contrast, dogs in the Open Door with Three Detour Demonstrations group remained faithful to the detour solution in trials 1–3. Placing the object through the opening might also have been too subtle an action and dogs might have been less attentive to it; alternatively it might have been functionally different from the action that would successfully solve the problem. In other words one hypothesis is that the demonstration of crawling through the fence would be more effective in inducing social learning.

Our experiments were not aimed at investigating the effect of human demonstration per se but the interaction of social and asocial factors during a detour task. The possible role of the demonstrator species, for example the ability of the dogs to learn from a dog demonstrator, remains a worthy topic to investigate in the future. However, it is clear that the behaviour of dogs in this problem-solving situation is the result of complex interacting processes that involve information gained by both social learning and individual experience.

### Acknowledgments

This work was supported by the Hungarian Foundation for Basic Research Grant No. T029705, and a grant from the Hungarian Academy of Sciences (F=226/98). The authors are grateful to Márta Gácsi (Top Manco Dog Training School), Katalin Timár-Geng (Hungarian Fényes Dezső Club of Mudi Breed), and Katalin Gurobi for their generous help in collection and analysing data, and we thank Dr Antal Dóka for the drawing of Fig. 1. We are grateful to two anonymous referees for their useful comments.

### References

- Adler, L. L. & Adler, H. E. 1977. Ontogeny of observational learning in the dog (*Canis familiaris*). *Developmental Psychobiology*, **10**, 267–271.
- Buytendijk, F. J. J. & Fischel, W. 1932. Die Bedeutung der Feldkräfte und der Intentionalität für das Verhalten des Hundes. *Archives Néerlande de Physiologie*, **17**, 459–494.

- Caro, T. M., Roper, R., Young, M. & Dank, G. R. 1979. Inter-observer reliability. *Behaviour*, **69**, 303–315.
- Frank, H. 1980. Evolution of canine information processing under conditions of natural and artificial selection. *Zeitschrift für Tierpsychologie*, **53**, 389–399.
- Galef, B. G. Jr 1995. Why behaviour patterns that animals learn socially are locally adaptive. *Animal Behaviour*, **49**, 1325–1334.
- Galef, B. G. Jr & Whiskin, E. E. 2001. Interaction of social and individual learning in food preferences of Norway rats. *Animal Behaviour*, **62**, 41–46.
- Gácsi, M., Topál, J., Miklósi, Á., Dóka, A. & Csányi, V. 2001. Attachment behaviour of adult dogs living in rescue centres: forming new bonds. *Journal of Comparative Psychology*, **115**, 423–431.
- Heyes, C. M. 1993. Imitation, culture and cognition. *Animal Behaviour*, **46**, 999–1010.
- Heyes, C. M. 1994. Social learning in animals: categories and mechanisms. *Biological Review*, **69**, 207–231.
- Kubinyi, E., Miklósi, Á., Topál, J. & Csányi, V. In press. Allelomimetic behaviour and social anticipation in dogs: preliminary results. *Animal Cognition*.
- Laland, K. N. 1996. Is social learning always locally adaptive? *Animal Behaviour*, **52**, 637–640.
- Laland, K. N. & Williams, K. 1998. Social transmission of maladaptive information in the guppy. *Behavioral Ecology*, **9**, 493–499.
- Laland, K. N., Richerson, P. J. & Boyd, R. 1996. Animal social learning: towards a new theoretical approach. In: *Social Learning in Animals: The Roots of Culture* (Ed. by C. M. Heyes & B. G. Galef Jr), pp. 129–154. San Diego, California: Academic Press.
- McBride, A. 1995. The human–dog relationship. In: *The Waltham Book of Human–Animal Interactions* (Ed. by I. Robinson), pp. 99–112. London: Pergamon.
- Magurran, A. E. & Higham, A. 1988. Information transfer across fish shoals under predator threat. *Ethology*, **78**, 153–158.
- Miklósi, Á., Polgárdi, R., Topál, J. & Csányi, V. 2000. Intentional behaviour in dog–human communication: an experimental analysis of ‘showing’ behaviour in the dog. *Animal Cognition*, **3**, 159–166.
- Palameta, B. & Lefebvre, L. 1985. The social transmission of a food-finding technique in pigeons: what is learned? *Animal Behaviour*, **33**, 892–896.
- Paxton, D. W. 2000. A case for a naturalistic perspective. *Anthrozoös*, **13**, 5–8.
- Pongrácz, P., Miklósi, Á. & Csányi, V. 2001a. Owner’s beliefs on the ability of their pet dogs to understand human verbal communication: a case of social understanding. *Cahiers de Psychologie Cognitive/Current Psychology of Cognition*, **20**, 87–107.
- Pongrácz, P., Miklósi, Á., Kubinyi, E., Gurobi, K., Topál, J. & Csányi, V. 2001b. Social learning in dogs: the effect of a human demonstrator on the performance of dogs, *Canis familiaris*, in a detour task. *Animal Behaviour*, **62**, 1109–1117.
- Slabbert, J. M. & Rasa, O. A. E. 1997. Observational learning of an acquired maternal behaviour pattern by working dog pups: an alternative training method? *Applied Animal Behaviour Science*, **53**, 309–316.
- Soproni, K., Miklósi, Á., Topál, J. & Csányi, V. 2001. Comprehension of human communicative signs in pet dogs. *Journal of Comparative Psychology*, **115**, 122–126.
- Soproni, K., Miklósi, Á., Topál, J. & Csányi, V. 2002. Dogs’ responsiveness to human pointing gestures. *Journal of Comparative Psychology*, **116**, 27–34.
- Zentall, T. R. & Hogan, D. E. 1978. Same/different concept learning in the pigeon: the effect of negative instances and prior adaptation to transfer stimuli. *Journal of Experimental Analysis of Behavior*, **30**, 177–186.

### Appendix: Breeds of Participating Dogs

- Closed Door without Detour Demonstration group (N=14)  
Border collie (2), German shepherd (2), Hungarian vizsla (2), husky (2), mudi (2) German pointer (1), giant schnauzer (1), kuvasz (1), pumi (1).
- Closed Door with Detour Demonstration group (N=14)  
Hungarian vizsla (2), mixed-breed (2), poodle (2), beagle (1), border collie (1), boxer (1), German shepherd (1), malinois (1), pointer (1), English cocker spaniel (1), Weimar pointer (1).
- Open Door without Detour Demonstration (N=10)  
Tervueren (4), Mudi (3), English setter (1), German shepherd (1), Groenendael (1).
- Open Door with Detour Demonstration (N=13)  
Tervueren (4), mudi (3), mixed-breed (2), poodle (2), Hungarian vizsla (1) kuvasz (1).
- Open Door with Three Detour Demonstration group (N=13)  
Boxer (2), kuvasz (2), poodle (2), tervueren (2), beagle (1), malinois (1), mixed-breed (1), German pointer (1), Weimar pointer (1).
- Closed Door group (N=11)  
German pointer (2), German shepherd (2), border collie (1), giant schnauzer (1), golden retriever (1), Hungarian vizsla (1), kuvasz (1), pumi (1), tervueren (1).
- Open Door with Single Detour Demonstration group (N=11)  
German shepherd (2), mixed-breed (2), tervueren (2), rough collie (1), German pointer (1), German Münsterland pointer (1), groenendael (1), Tibetan terrier (1).